

## SUSPENSION

### DESCRIPTION

As in the '02 RAV4, a MacPherson strut type independent suspension is used for the front and double wishbone type independent suspension is used for the rear.

However, due to the increase in the vehicle weight of the RAV4 EV, the bushings' spring characteristics and the shock absorbers' dampening force have been optimized and the front suspension member has been changed to provide excellent riding comfort.

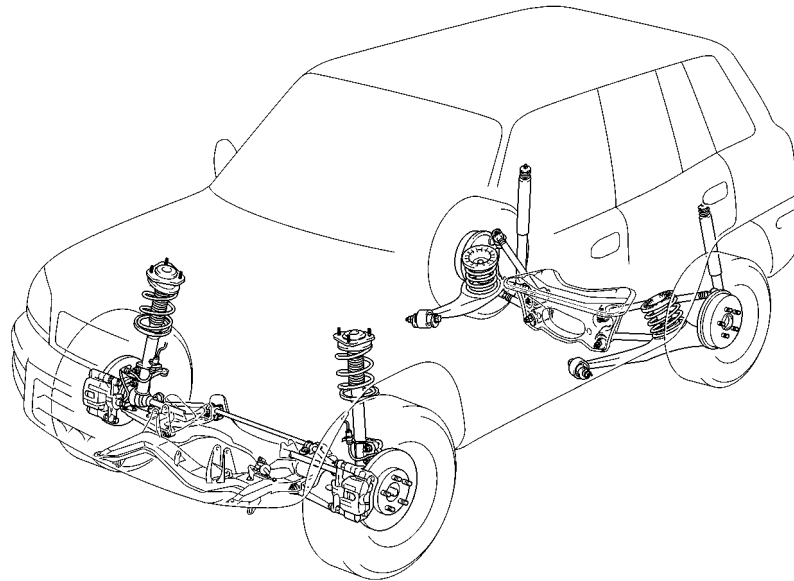

153CH32

### ► Specifications ◀

Model		RAV4 EV	
Item			
Front Suspension	Type	MacPherson Strut	
	Tread	mm (in.)	1460 (57.5)
	Caster*	degrees	1° 36'
	Camber*	degrees	-0° 19'
	Toe-In*	mm (in.)	-0.6 (-0.02)
	King Pin Inclination*	degrees	10° 31'
Rear Suspension	Type	Double Wishbone	
	Tread	mm (in.)	1450 (57.1)
	Camber*	degrees	-0° 50'
	Toe-In*	mm (in.)	1 (0.04)

\*: Unloaded Vehicle Condition